

OPERATION MANUAL

V5 NON-CONDUCTIVE VIDEOSCOPE SYSTEM

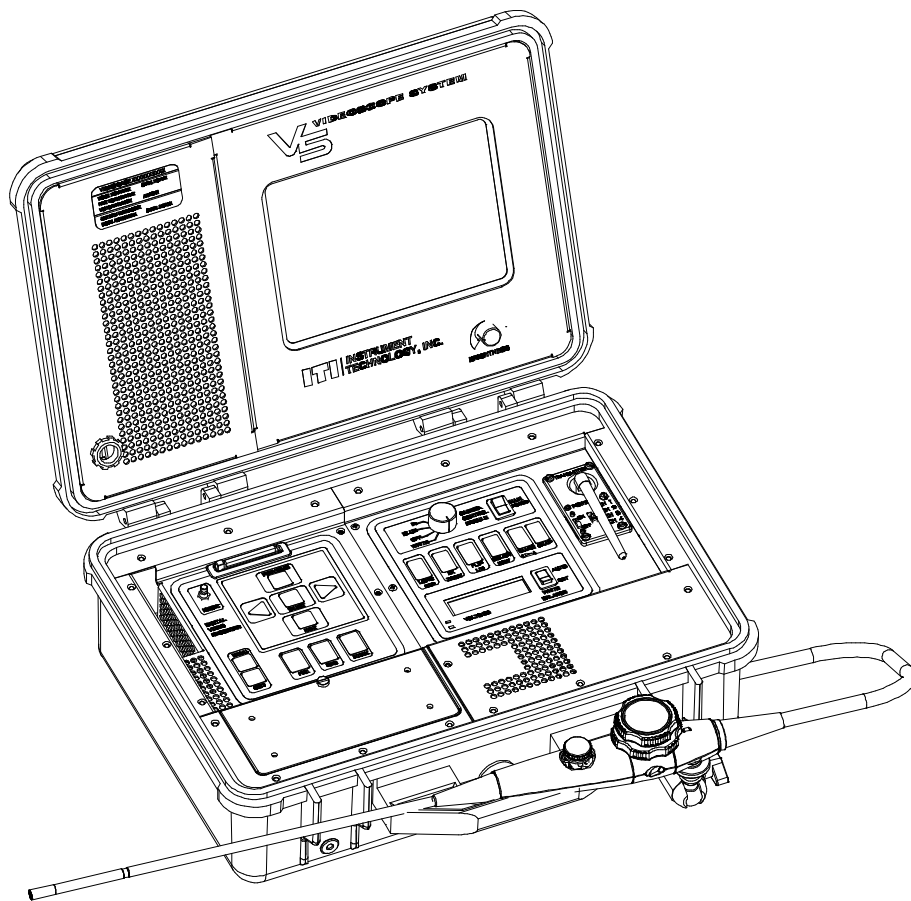

ITI | INSTRUMENT
TECHNOLOGY, INC.

POB 381, Westfield, MA 01086
33 Airport Road, Westfield, MA 01085

Tel: (413) 562-3606

Fax: (413) 568-9809

Email: iti@scopes.com

www.scopes.com

v. 110606

TABLE OF CONTENTS

Introduction	4
Product Specifications	5
1.0 Product Overview	7
2.0 Setup Assembly	8
3.0 Videoscope	9
Focus	9
Articulation.....	9
Articulation Locks	9
4.0 Video Camera Control Panel	10
5.0 Digital Video Recorder	12
Inserting or Removing the CompactFlash Card	12
Using the MAIN MENU.....	13
System Setup	13
Utilities Section	14
Video Settings	15
File and Folder Options	17
Capturing Images and Video	18
Capturing a Still Image	18
Capturing a Video Clip	19
Storage Capacity	19
Displaying Captured Images and Video	19
Using the Image Gallery	19
Using the Gallery Menu	21
Adding Text Annotation	23
Using the OSD Text Editor	23
Storing Standard Annotation	24
Adding Audio Annotation.....	25
Setting Up Audio.....	25
Transferring Captured Images and Video to a PC	26
Installing a Card Reader	26
Formatting a CompactFlash Card	26

Copying Files to the PC	27
Copying Files to the CompactFlash Card	27
6.0 Video Display	27
Display Options	28
7.0 Battery and Charger	28
Charging the Batteries inside the Videoscope Case	28
Charging the Batteries outside the Videoscope Case	29
Battery Charger.....	30
8.0 Light Sources	31
White Light Source.....	31
Lamp Replacement.....	31
Blue Light Source.....	32
Infrared Light Source	32
9.0 Headphone Set.....	33
10.0 4" Monitor, Handle Mounted (Option)	34
Operating Instructions	34
11.0 Wireless Link (Option).....	35
Transmitter Video Case.....	35
Receiver Pack.....	36
12.0 Head Up Display (Option).....	37
Specifications.....	37
HUD Setup.....	37
13.0 Troubleshooting Guide	38
14.0 Instrument Care and Repair Policy	39

INTRODUCTION

Thank you for selecting Instrument Technology, Inc. (ITI) to fulfill your remote viewing needs.

Since 1967, ITI has been the Leader in Remote Viewing. The only company of its type doing all its manufacturing in the United States, ITI consistently provides cutting edge technology to customers world-wide.

ITI specializes in the design, development and manufacture of Remote Viewing Instruments (RVI) and systems including Borescopes, Fiberscopes and Videoscopes.

ITI offers over 2,000 standard products as well as products custom designed for unique applications. No matter which ITI product is used, our customers find they are able to observe hostile and difficult to reach environments never dreamed possible before. Though ITI products can solve many remote viewing problems, it is always best to select the proper instrument for any given application. Only then can success be assured.

Your satisfaction is guaranteed with all products purchased from Instrument Technology, Inc. Feel free to contact ITI or your local ITI Representative with any questions.

WARRANTY

Instrument Technology, Inc. warrants that the equipment is fit for the purposes described herein for a period of one year after the date of shipment when used in accordance with the directions for use, and agrees to repair or replace any such defective component part at no cost to the customer.

There are no other express or implied warranties. ITI's sole obligation and purchaser's exclusive remedy for breach of any warranty shall be limited to repair or replacement of the product at the option of ITI. This warranty does not cover, and ITI will not be liable for any resulting direct, proximate, incidental or consequential damages. This warranty does not apply if the product has been subject to misuse, negligence, accident or improper application, nor shall ITI be responsible for work done or repairs made by others.

▲ WARNING: Read this manual completely.

SAFETY INFORMATION DEFINITIONS

- **▲DANGER:** Indicate[s] a hazardous situation which, if not avoided, will result in death or serious injury. The signal word "DANGER" is to be limited to the most extreme situations. DANGER [signs] should not be used for property damage hazards unless personal injury risk appropriate to these levels is also involved.
- **▲WARNING:** Indicate[s] a hazardous situation which, if not avoided, could result in death or serious injury. WARNING [signs] should not be used for property damage hazards unless personal injury risk appropriate to this level is also involved.
- **▲CAUTION:** Indicate[s] a hazardous situation which, if not avoided, could result in minor or moderate injury.

CAUTION: [Signs] without a safety alert symbol may be used to alert against unsafe practices that can result in property damage only.

- **NOTICE:** [this header is] preferred to address practices not related to personal injury. The safety alert symbol shall not be used with this signal word. As an alternative to "NOTICE" the word "CAUTION" without the safety alert symbol may be used to indicate a message not related to personal injury.

PRODUCT SPECIFICATIONS

ITI Non-Conductive Videoscope Kit includes:

- (1) ITI Model 178708 Ø8mm Non-Conductive Videoscope
- (1) ITI Model 178310 V5 Video Case
- (2) Battery Pack P/N 120903
- (2) Battery Charger P/N 120866-3
- (1) Videoscope Mount P/N120968
- (1) Receiver (Optional) P/N 120890
- (1) Head Up Display Kit (Optional) P/N 122354
- (1) Spare Light Source Bulb P/N 408-078
- (1) Headphone Set with Microphone P/N 704-006
- (1) 2.5mm Plug to Jack Patch Cord P/N 704-007
- (1) ½" Dekoron Hose P/N 914-010
- (1) Protective Carrying Case & Foam

Videoscope

Physical Specifications

Diameter	8.0mm nominal
Lengths, Available	2, 3, 4, 5, 6, 7, and 7.5 meters
Articulation Angulation	120° minimum (Up, Down, Left, and Right)
Mounting attachment	¼" - 20 UN - 2B thread

Optical Specifications

Field of View	80 degrees fixed
Line of Sight	0° Forward
Depth of Field	25mm to Infinity

Video Specifications

TV System Format	NTSC
Image Sensor Size/Type	1/6"/CCD
Effective Pixels	373K NTSC, 438K PAL
S/N Ratio	46dB minimum
Electronic Shutter	Variable from 1/30 - 1/10,000 sec.
White Balance	Auto and Manual (3200 °K to 6300 °K)

Video Case

Digital Recording

Video	Motion-JPEG (Quicktime MOV files, CIF) NTSC – 320 x 240, 30fps PAL – 384 x 288, 25fps Two recording rate settings: 33 mins (4mbit/s) w/ 2GB CF card 66 mins (2mbit/s) w/ 2GB CF card
Audio	Audio annotations recorded w/ video
Still Images	JPEG file type NTSC – 640 x 480 PAL – 768 x 576 Two image snap settings: Standard Quality (128kB file size) High Quality (256kB file size)

Storage Media	CompactFlash™ Type I and II cards 1 GB (included) up to 2GB max. capacity
Display	
Size and Type	10.4" TFT Color LCD
Viewing Angle	45° Up, 55° Down, 70° Left, 70° Right
Luminance	450 cd/m ² (450 NITS)
Contrast Ratio	600:1
Resolution	VGA (640H x 480V)
Light Source	
Lamp	24 Watt Solarc
Color Temp	5500 °K
Lamp Life	500 hours
Attenuation	Manual graduated shutter
Video and Accessory I/O	
Video Input	S-video (Y/C), 4-pin mini-DIN
Video Output	S-video (Y/C), 4-pin mini-DIN Composite (CVBS), BNC Scope mounted ITI Monitor
Keyboard Input	PS/2 6-pin mini-DIN
Audio Headset Input	2.5mm phone jack
Misc. Features	
Electronic Zoom	2X Digital Zoom
Image Inversion	Left to Right Mirror
Longtime Exposure	1/30 to 2.1 sec.
Display	Freeze Frame 4-Image tiled mosaic Color/Black & White Positive/Negative
Text Overlay	10 lines x 25 characters

General Specifications

Power Requirements

Alternating Current	120 VAC, 650 mA, or 240 VAC, 325 mA (option)
Direct Current	12 VDC, 6A
Battery Runtime	2 hours (10.8Ahr NiMH)

Environment

Operating Temp, Case	-5°F to 115°F (-20 to 46°C)
Operating Temp, Probe	-13°F to 176°F (-25°C to 80°C)
Operating Humidity	95% RH maximum
Storage Temp	-15°F to 140°F (-26°C to 60°C)

Physical

Weight, Videoscope	2 lbs. (.91 Kg) – 2 meters length
Weight, Video Case	25 lbs. (11.3 Kg)
Dimensions, Video Case	18-1/2" x 14" x 7" (470mm x 356mm x 178mm)

1.0 PRODUCT OVERVIEW

ITI Series 178708 Videoscopes are long, small diameter, flexible tubes containing a high resolution color camera chip with lenses at the distal tip. The chip camera carries video signals by wires that terminate in a multi-pin connection extending from the operation handle. The flexible tube also contains:

- 1) 4-way articulation wires enabling distal tip movement.
- 2) Fiber optics for illumination.

The flexible tube is composed of an internal coil for crush resistance, braided wall reinforcement for torsional strength, and a plastic external layer as a flexible and environmental resistance seal. Videoscope models also employ a tungsten metal exterior braid for durability in sharp edged and abrasive environments. Other models use only non-conductive external materials to prevent shorting of electrical equipment being viewed.

⚠ DANGER: Always consult this manual and ITI representatives before employing this product in a high electrical powered application to prevent injury or death.

Videoscopes are normally used to view or inspect into inaccessible or hazardous environments when only limited access is available. The articulation control enables the operator to move the tip around for general observation and/or inspection.

The Videoscope is connected to the V5 Videoscope System. The V5 contains the controls to operate the Videoscopes camera (see Figure 1).

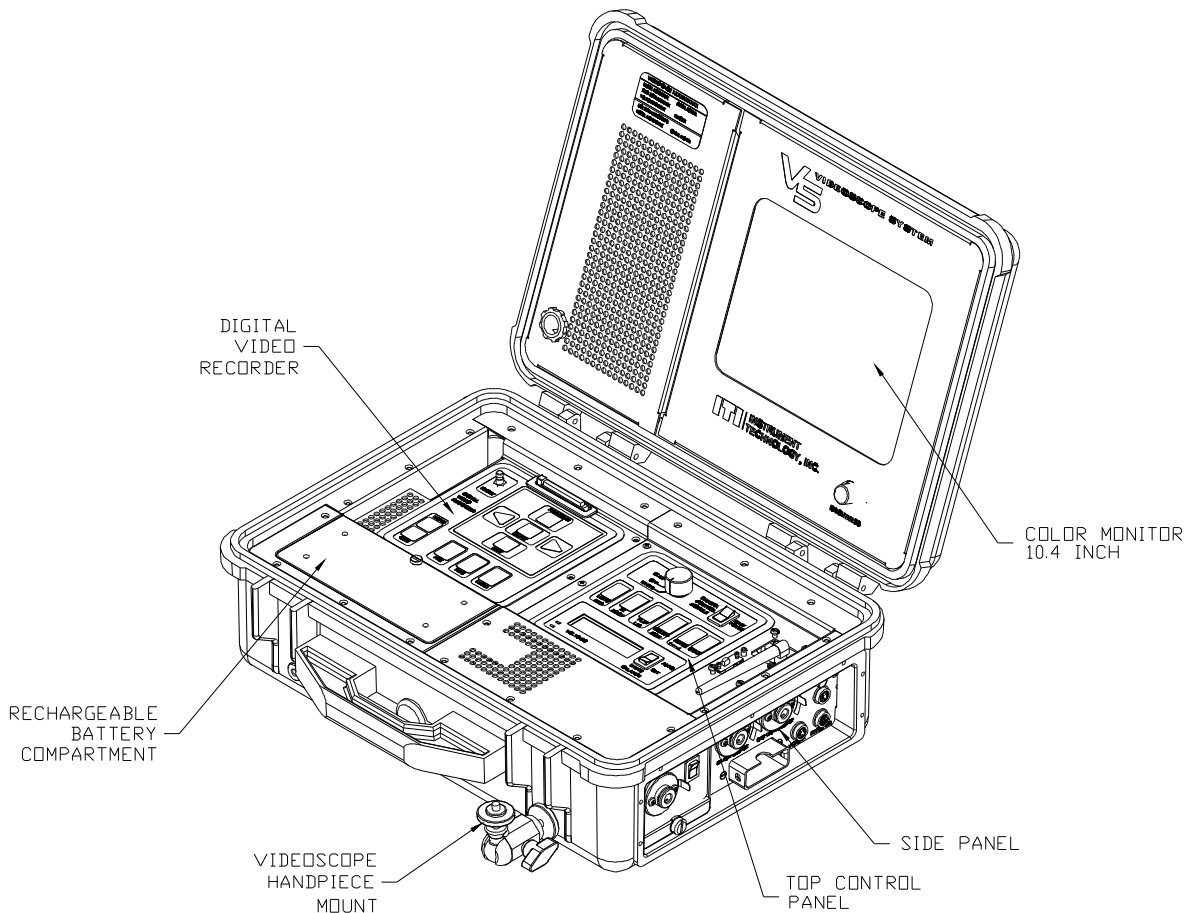

Fig. 1: V5 Videoscope Controls System

2.0 SETUP ASSEMBLY

CAUTION: Never attach or remove the Videoscope portion of the V5 System from the Video Case control portion when powered (ON) as the camera system will be damaged. The system must always be shut off and preferably removed from Mains power connection, prior to setup or disassembly.

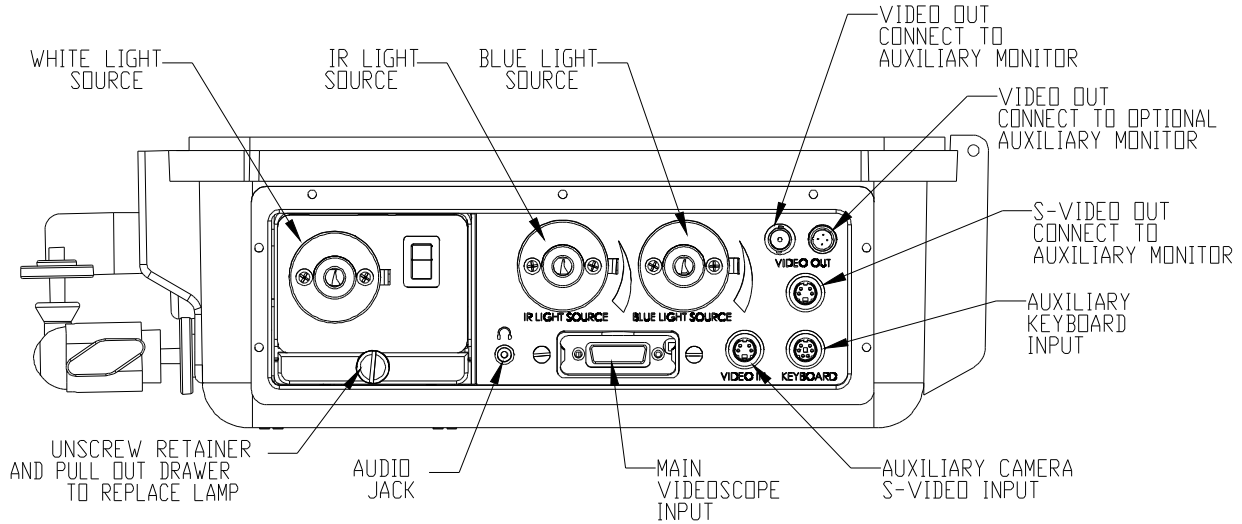

Fig. 2: Side Panel

1. Connect the Videoscope control cable video connector into the Main Videoscope Input connector located on side of **V5 Videoscope System (V5)** shown in Fig. 2 above.
2. Connect the second connector, Videoscope control cable Light Input, into Light Source to be used. Each light source has an illumination attenuation lever to shutter down the light intensity, adjust as needed.
3. Assuming the system will use the internal DC Battery Packs for power the V5 Videoscope System is set and ready for operation. See Top Control Panel section for operation instructions to operate.
4. If AC power is to be used, please connect the AC power cord to the system's AC input located on the rear panel, see Fig. 7. Next, plug the supply end of the cord into the proper voltage supply.

CAUTION: Reference the power input configuration tag located on the inside lid panel or located near the rear panel connections. Failure to use a cord and a proper voltage supply could result in property damage or personal injury.

5. (OPTION) For those units equipped with the video monitor handle connection and its associated input connector located as the third connector at the end of the handle's video control cable, to operate the handle monitor requires the cable connection to be attached to the Auxiliary Monitor input located on the side panel.

3.0 VIDEOSCOPE

FOCUS

The objective lens in the Videoscope is fixed and cannot be adjusted. An object will be in focus if it is between 1.0 inch and infinity.

ARTICULATION

CAUTION: DO NOT ATTEMPT TO ARTICULATE VIDEOSCOPE IN THE COILED STATE, CATASTROPHIC FAILURE TO THE ARTICULATION SYSTEM WILL OCCUR FROM ADDED STRESSES PLACED ON THE SYSTEM. THE WORKING LENGTH OF THE INSTRUMENT SHOULD BE IN THE ELONGATED STATE AT-ALL-TIMES WHEN ARTICULATING THE INSTRUMENT.

The Videoscope has four-way articulation (up, down, left and right). The knobs on the handpiece control the articulation, see Fig. 3. Rotate one knob to articulate up/down, and rotate the second knob to articulate left/right.

The Videoscope articulation system is considered at its “neutral position” when the distal end is lying in line with the working length. When neutral, the neutral dots on the Articulation Knobs should be in line with each other and the white neutral indicator line on the rear body housing. **The scope should always be returned to this position prior to withdrawal from area being viewed.**

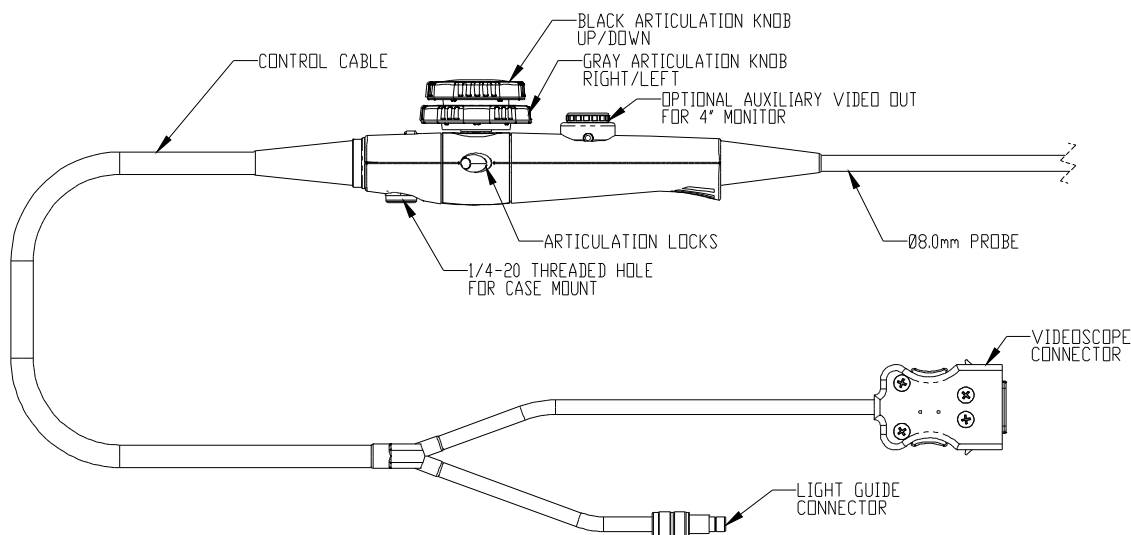

Fig. 3: Videoscope Handle Features

ARTICULATION LOCKS

Once an object has been acquired in the field of view, line of sight may be maintained by using articulation locks. Locks are oval rocking levers located to the side of knobs. Each knob has its own color-coded lock to switch on or off.

When “ON”, the ratchet style locking system engages, while the “OFF” position allows Videoscope to articulate freely. The ratchet system holds the line of sight. It can also be overpowered by turning the knob to the next locking position. The operator will hear an audible click as the knob is advanced from position to position. This is the ratchet mechanism at work.

CAUTION: Always unlock and straighten Videoscope before withdrawal. Failure to do so may result in catastrophic failure. Scope is straight when the knobs are returned to their neutral position.

4.0 VIDEO CAMERA CONTROL PANEL

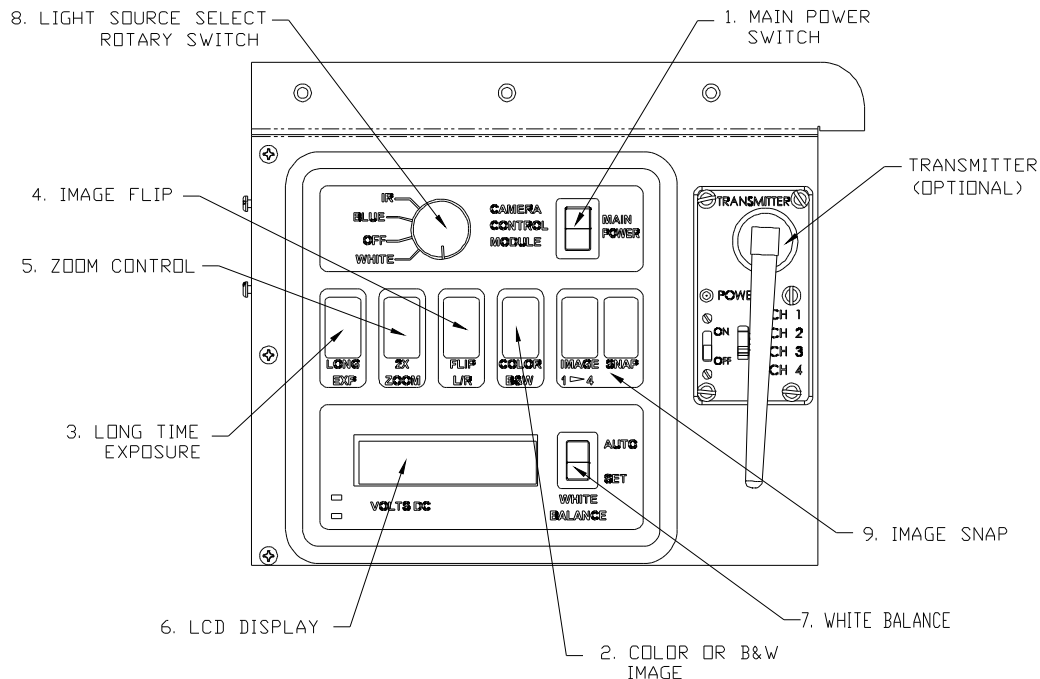

Fig. 4: Camera Control Panel

FEATURES

1. Main Power Switch

This switch turns ON and OFF both external AC and internal 12VDC circuits.

2. Color or B&W Image

Switches between Color or Black & White, Negative or Positive Images.

3. Long Time Exposure (LTE) (Labeled EXP)

You can make the LTE settings in 7 increments within the range from 2 Frames (1/30s) through maximum 128 Frames (approx. 2.1s). The LTE setting number is displayed on the LCD Panel. The LTE is effective to view extremely dark subjects without much motion.

4. Image Flip Function

This switch flips the image right to left to produce a mirror image. Push the switch to toggle between views.

5. Electronic Zoom

The camera is equipped with electronic Zoom to view subjects close up. This switch toggles between two positions 1X and 2X.

6. Temperature, Battery Voltage & Long Time Exposure Display - LCD info screen

Probe Temperature

The top line of the display shows the temp of the sensor in the end of the VS probe. If the temp gets too high the LCD will display a high temp warning and the yellow LED will flash. The probe should be withdrawn and allowed to cool. If the probe is not removed and is continues to get hotter the warning "REMOVE SCOPE" will be displayed and the red led will flash. If the probe is not withdrawn and cooled permanent damage to the camera will result. After the probe has returned to normal operating temp the display will show the message "PLEASE RESTART SYSYEM". To reset turn the unit off at the main power switch and then back on.

Battery Voltage

The second line on the LCD will display the system voltage. If the system is running on external AC power the display will show a constant voltage of about 12VDC. However if the system is running on the external battery pack then the display will show the voltage of the battery. When the battery pack reaches the end of its charge the LCD will display "LOW BATTERY" and the yellow LED will flash. At this point the system should be turned off and the battery recharged (see Battery and Battery Charger Description and Operation). If the system is allowed to run longer the red LED will start flashing and soon after the system will not function properly as the battery voltage will be too low.

Long Time Exposure

When the long time exposure (LTE) mode is being used (see Fig. 3) the top line on the LCD will also display which step number the LTE is at. There are a possible 7 steps in LTE mode so the display will show step 1 through 7. If a low battery or high temp warning is displayed the LTE will still work but the step number will not be displayed and during this time any LTE key presses will cause the display and actual LTE settings to be out of synchronization. For the LTE readout to function properly (in sync) again the warning problem must be solved and the system reset.

7. White Balance

The camera is equipped with the AUTO / SET White Balance. AUTO mode detects the color-temperature of a subject to automatically adjust White Balance. The SET mode locks the White Balance, which is good for viewing in fixed color-temp illumination, such as the Blue and IR illumination. The White Balance should be used in the SET mode under most conditions. Each time the V5 is used set up the White Balance. To set up: start in AUTO mode while viewing a well lit white surface illuminated with white light, then push the switch to change to SET mode.

8. Illumination Select Rotary Switch

This rotary switch has four positions allowing each light source to be powered individually. Only one light source can be powered at a time. This switch should be kept in the OFF position if a light source is not required. The light sources create a lot of heat and will deplete the batteries rapidly.

9. Image & Snap Function

When the IMAGE button is pressed, the screen will split in 4 images. One image is live while the other three are frozen. By pressing the SNAP button, the live image will progress around the screen, and the previous live image will be frozen. Push the IMAGE button again, and the screen will return to normal. If the SNAP button is pushed when not in the 4 screen mode, it will freeze the live image.

5.0 DIGITAL VIDEO RECORDER

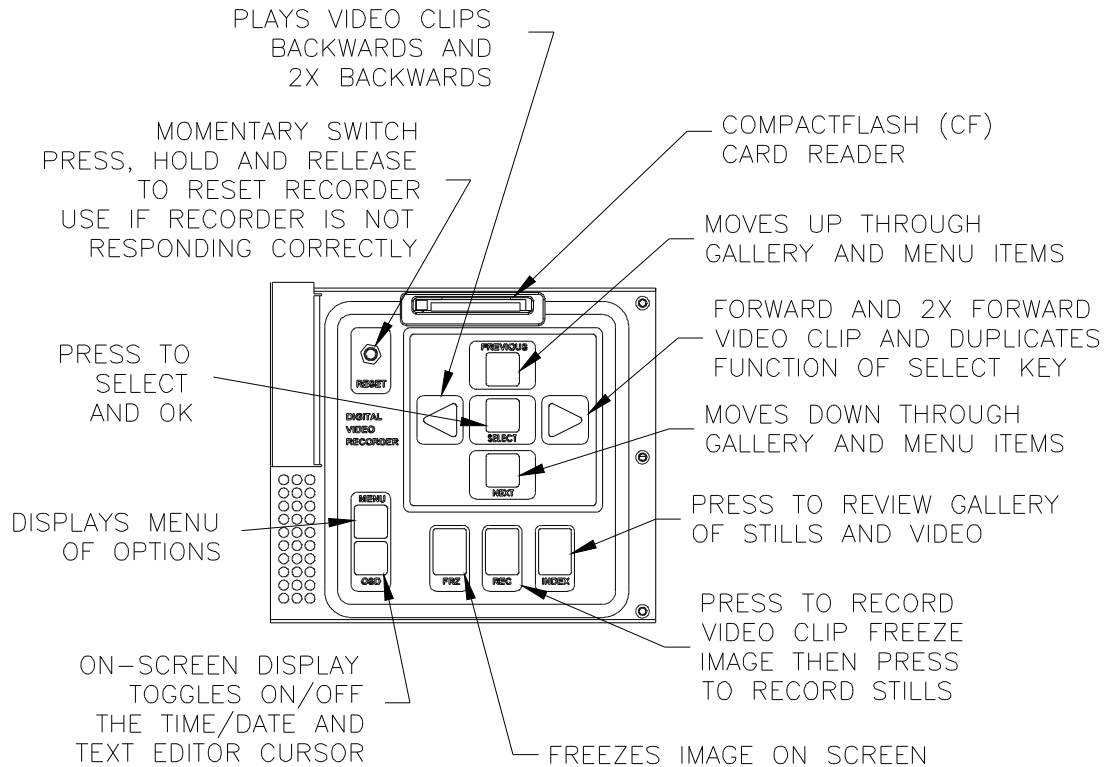

Fig. 5: Digital Video Recorder Control Panel

Using the Menus

The Digital Video Recorder (DVR) is operated using the keys in conjunction with a series of on-screen menus.

To display the main Menu

- Press **MENU**

To move between options

- Press **PREVIOUS** or **NEXT**

To select an option

- Press **▶** or **SELECT**

To exit from the current menu

- Press **MENU**

Inserting or removing the CompactFlash Card

The CompactFlash card can be removed or plugged in even while the **V5 Videoscope System** is switched on.

After plugging in a CompactFlash card the screen will blink for a few seconds while the **V5 Videoscope System** reads the data on the card; you can then proceed as normal.

NOTICE: Before you can use a new Compact Flash card it must be formatted: see “*To format a Compact Flash card.*”

Using the MAIN MENU

To display the MAIN MENU

- Press **MENU**

System setup

.....

The **SETUP MENU** allows you to set the date and time, and adjust the video display setting and picture lock:

SETUP MENU		

DATE	<290105>	DDMMYY
TIME	<141620>	HHMMSS
DEFAULT BEEP		<1>
CONTRAST		<5>
BRIGHTNESS		<5>
COLOUR		<5>
PLL TUNING		<5>

To set the date and time

- Press **PREVIOUS** or **NEXT** to highlight the current date or time, and press **▶** or **SELECT**

The first digit of the date is highlighted with a flashing cursor.

- Use **PREVIOUS** or **NEXT** to change the current digit
- Press **▶** or **◀** to move between digits

When you have set the correct date or time:

- Press **SELECT** to exit from editing mode.

To turn on or off the keypress beep

- Press **PREVIOUS** or **NEXT** to highlight **DEFAULT BEEP** and press **▶** or **SELECT** to select it
- Press **PREVIOUS** or **NEXT** to toggle between 0 (no beep) or 1 (beep).

To change the video parameters

The video settings **CONTRAST**, **BRIGHTNESS**, and **COLOR** allow you to adjust the image you are saving to compensate for deficiencies in the video source.

- Press **PREVIOUS** or **NEXT** to highlight the parameter you want to change, and press **▶** or **SELECT** to select it.

The current value is indicated by a flashing cursor.

- Press **PREVIOUS** or **NEXT** to change the setting

You can edit each setting between 0 and 9, where 5 is the default value.

- Press **▶** or **SELECT** to exit from editing mode

Note that the settings revert to their defaults next time you switch the **V5 Videoscope System** on.

To adjust the picture lock

Allows you to lock the **V5 Videoscope System** to an external monitor.

- Press **PREVIOUS** or **NEXT** to highlight **PLL TUNING** and press **▶** or **SELECT** to select it.
- Press **PREVIOUS** or **NEXT** to adjust the picture lock between 0 and 9, where 5 is the default value.

Generally, higher values will improve the lock.

Utilities Section

.....

To select the language

MAIN MENU	

VIDEO STANDARD	>
IMAGE FREEZE	>
RECORD TIME	>
BASE FILENAME	>
DISPLAY ORIENTATION	>
LANGUAGE	>
SETUP	>
FORMAT	>
FOLDER	>
+FOLDER	>
RENAME FOLDER	>
LARGE OSD FONT	>
BACKLIGHT	>

SELECT
ENGLISH
DEUTSCH
FRANCAIS
ESPANOL
ITALIANO

Allows you to select the on-screen menu language.

This setting is retained when the **V5 Videoscope System** is switched off.

To select the large OSD font

MAIN MENU	

VIDEO STANDARD	>
IMAGE FREEZE	>
RECORD TIME	>
BASE FILENAME	>
DISPLAY ORIENTATION	>
LANGUAGE	>
SETUP	>
FORMAT	>
FOLDER	>
+FOLDER	>
RENAME FOLDER	>
OSD	>
BACKLIGHT	>

SELECT
OFF
ON

Allows you to select a larger OSD font, for annotation overlays

To set the BACKLIGHT brightness

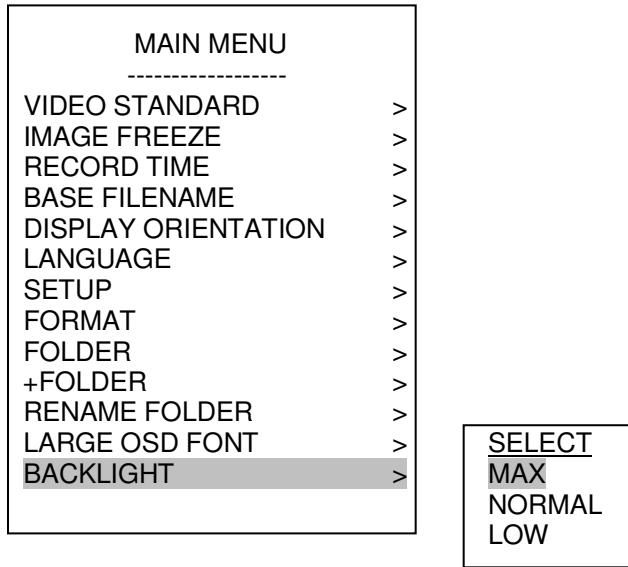

By default the **BACKLIGHT** is set to **MAX** or maximum brightness. To improve battery life, or for working in low light conditions, you can set the brightness to **NORMAL** or **LOW**. The current setting is displayed in the center of the top line of the OSD display.

Video Settings

.....

To specify the video standard for replaying images

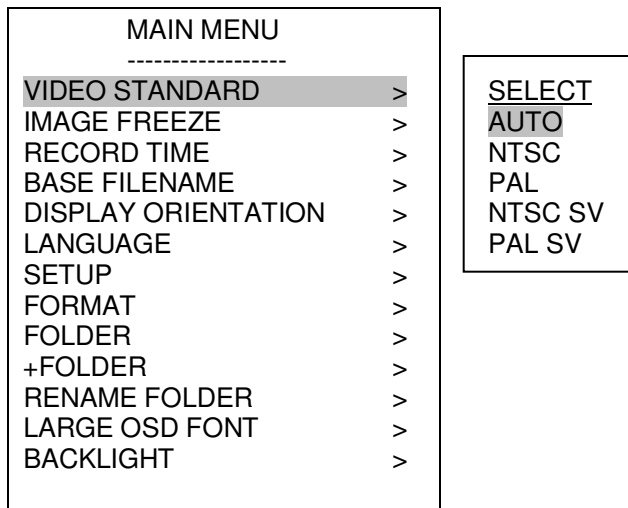

○ Choose **AUTO** for auto-detection of the video standard from the current video input, **NTSC** for NTSC composite, **PAL** for PAL composite, **NTSC SV** for NTSC S-Video, or **PAL SV** for PAL S-Video.

This setting is retained when the **V5 Videoscope System** is switched off.

Normally, **AUTO** is the recommended setting; with this option, the **V5 Videoscope System** automatically sets the standard based on the current video source, and retains the settings even when the video source is disconnected. However, you can only replay images saved with the current video standard.

If you want to replay images on the **V5 Videoscope System** of either standard, without a video input connected, set the **VIDEO STANDARD** option to **NTSC** or **PAL** as appropriate.

To specify the image freeze mode

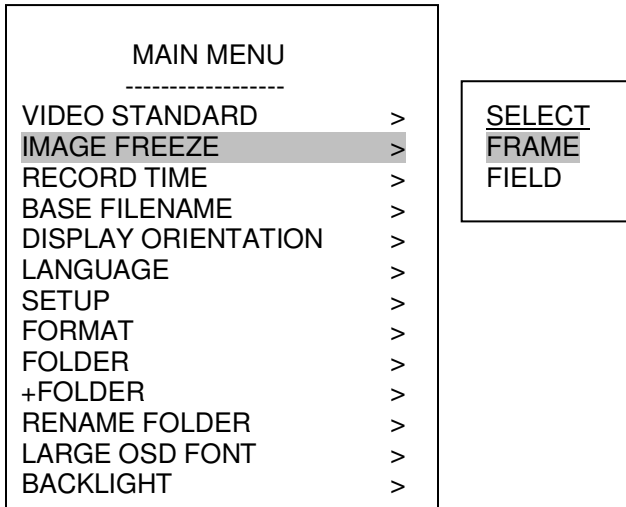

By default the **IMAGE FREEZE** option is set to **FRAME**, which captures both frames of the video image. You can override this on an individual image basis; see *"To select double-field mode."*

The **FIELD** option sets double-field mode for all images by default. This is useful if most images you capture are of moving objects.

To specify the record time

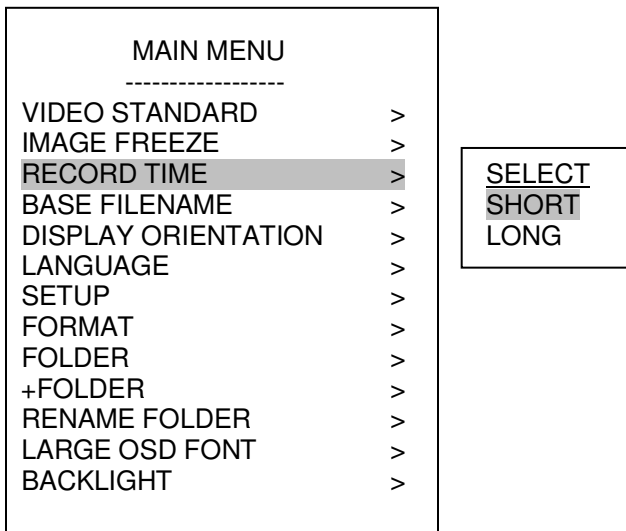

Allows you to select the frame rate of video clips.

SHORT gives 30 fps (NTSC) or 25 fps (PAL).

LONG gives 15 fps (NTSC) or 12.5 fps (PAL).

The corresponding recording times are displayed when you press **RECORD**.

File and folder options

.....

You can specify a six-character filename prefix instead of the default date prefix.

You can also create folders, and select a current folder, to organize the images and video clips.

The base filename and current folder are retained when the **V5 Videoscope System** is switched off.

To specify the base filename

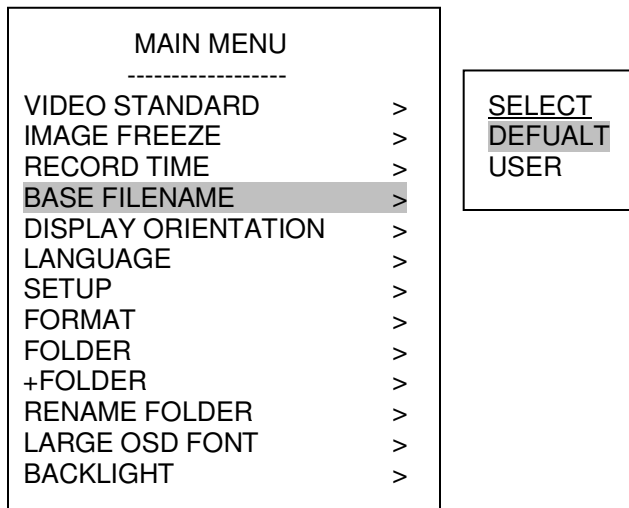

- Select **DEFAULT** to save each file with a six-character prefix, consisting of the current date in the appropriate format.
- Select **USER** to specify a six-character prefix.

The following dialog box allows you to enter the prefix using the **PREVIOUS**, **NEXT**, and **▶** or **SELECT** keys:

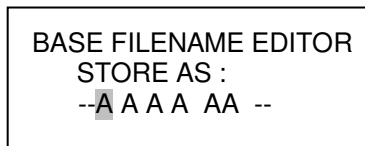

To select the current folder

- Select **FOLDER** on the **MAIN MENU**.

The **SELECT FOLDER** sub-menu shows a list of the names of the folders on the CompactFlash card.

- Use the **PREVIOUS** or **NEXT** keys to highlight the folder you want to use and press **▶** or **SELECT** to select it.

To create a new folder

- Select **+FOLDER** on the **MAIN MENU**, then proceed as described in *"To create a new folder."*

To rename a folder

- Select **RENAME FOLDER** on the **MAIN MENU**, then proceed as for renaming a file; see *"To rename a file."*

Capturing Images and Video

Capturing a still image

.....

To freeze the image

- Press **FREEZE**

When the image is frozen the display shows **STILL**

- Press **FREEZE** again to unfreeze the image.

NOTE: With a PAL video signal, the **V5 Videoscope System** display shows a slightly cropped version of the image. However, the captured image is full size.

To select double-field mode

If the frozen image appears to jitter, due to movement between the two fields of the full frame image, the **V5 Videoscope System** allows you to double-up a single field to remove the jitter.

- Press **▶** or **SELECT** while the image is frozen

One of the two sequential fields is then doubled up to create a flicker-free image at half the resolution.

The display shows **DOUBLE-FIELD MODE** to show that only one field will be saved.

You can configure the **V5+ Videoscope System** to save all images in double-field mode; see *“To specify the image freeze mode.”*

To save the image

- While the image is frozen press **RECORD (REC)**

The **FILENAME EDITOR** is briefly displayed to show the filename assigned to the image, and the space remaining.

FILENAME EDITOR
STORE AS:
-0128030V-
FILE SPACE LEFT: 0126

If the image is in double-field mode a **D** is displayed in the top right-hand corner of the **FILENAME EDITOR**.

The first six characters of the filename will be the current date in the US format (NTSC video) or UK format (PAL video); for example 250604. Alternatively you can supply a six-character prefix using the **BASE FILENAME** option on the **MAIN MENU**; see *“To specify the base filename.”*

The last two characters of the filename are automatically incremented through the sequence of characters 0-9 and A-Z to ensure that every file is saved with a unique name. For example, the first few filenames will end in 00, 01, 02 09, 0A, 0B 0Z, 10, 11 etc.

Capturing a video clip

.....

To capture a video clip

- Press **RECORD**

The display shows the maximum length of video clip you can capture, depending on the amount of space remaining on the CompactFlash card.

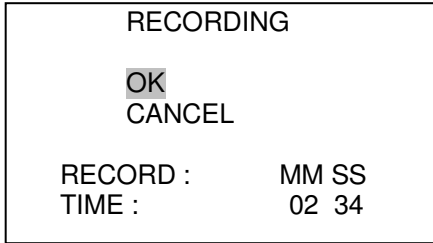

- Press **SELECT** to select OK and start recording.

Alternatively, to cancel video capture press **NEXT** to highlight **CANCEL** and press **▶** or **SELECT** to select it, or press **MENU**.

While video is being captured the display shows **RECORDING**:

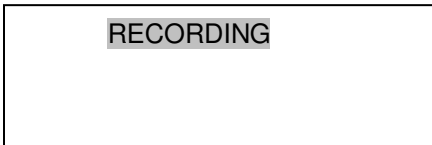

To pause recording:

- Press **FREEZE**

The **RECORDING** overlay flashes to indicate that the recording is paused.

- Press **FREEZE** to resume recording

To stop recording:

- Press **RECORD**.

Storage Capacity

.....

The PalmScope is provided with a preformatted blank 512MB CompactFlash card. To use other CompactFlash or IBM MicroDrive cards with the **V5 Videoscope System**, they should first be formatted as described in *"To format a CompactFlash card."*

Displaying Captured Images and Video

Using the image gallery

.....

The image gallery allows you to review the still images and video clips you have captured, and provides commands to help you to organize the images.

When replaying still images and video clips, the **V5 Videoscope System** automatically switches between NTSC and PAL mode, depending on the format used to capture them.

If you have a live video signal connected, you will need to unplug it to display images in the other format.

To display the image gallery

- Press **INDEX**.

The display briefly shows:

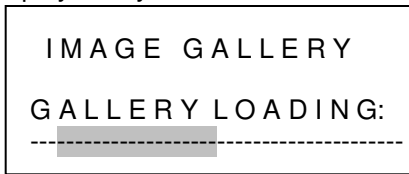

It will show thumbnail previews of the 12 most recent images you have captured in the current folder:



A flashing filename indicator highlights the most recently captured image. For video clips the thumbnail shows the first frame, and a play icon is displayed in the lower left corner.

To highlight a thumbnail:

- Move the filename indicator with **PREVIOUS** or **NEXT**.
- Hold down either key to move quickly between the images.

You can step through the 12 thumbnails in the gallery, and as you highlight each thumbnail, the filename indicator changes to show the full filename of that image or video clip.

To display the previous page of thumbnails:

- Move the filename indicator to the first thumbnail in the top left corner of the image gallery, and press **PREVIOUS**.

After a **GALLERY LOADING** message, the next page of 12 thumbnails will be displayed. If there are no more images in the current folder, the filename indicator will wrap to the last image in the lower right corner of the image gallery.

To display the next page of thumbnails:

- Move the filename indicator to the last thumbnail in the lower right corner of the image gallery, and press **PREVIOUS**.

After a **GALLERY LOADING** message, the next page of 12 thumbnails will be displayed. If you are already displaying the most recent files in the current folder, the filename indicator will wrap to the first image in the top left corner of the image gallery.

To display an image at full size, or replay a video clip:

- Highlight the thumbnail of the file you want to display.
- Press ► or **SELECT**

The image or video clip will be displayed at full size.

While a full size image is being displayed, or after a video clip has finished playing, you can use the following keys:

KEY	FUNCTION
PREVIOUS	Steps to the next image.
NEXT	Steps to the previous image.
MENU	Displays the RETRIEVAL menu to allow you to delete or rename the image.
INDEX	Returns to the image gallery.

While a video clip is playing or paused, you can use the following keys to control playback, and an indicator in the top right-hand corner of the display, indicates the current playback mode:

KEY	FUNCTION
FREEZE	Pauses (indicator flashes) or continues playing. Hold down FREEZE to single-step.
►	Plays forward at normal (>) or double speed (>>).
◄	Plays backwards at normal (<) or double speed (<<).
INDEX	Returns to the image gallery.

NOTICE: Images captured in PAL format are slightly cropped when displayed on the **V5 Videoscope System** display. However, the stored images are full size.

To exit from the image gallery:

- Press **FREEZE**.

Using the GALLERY menu

.....

You can manipulate the images displayed in the gallery, by using the options on the **GALLERY** menu. The following table summarizes the options:

OPTION	DESCRIPTION
MARK	Allows you to mark several thumbnails and then apply a function to all the marked files.
MOVE	Moves the selected file or marked files to another folder.
COPY	Copies the selected file or marked files to another folder.
RENAME	Renames the selected file.
FOLDER	Changes the current folder.
+FOLDER	Creates a new empty folder.

To select the GALLERY menu:

- Press **MENU**

The first option on the **GALLERY** menu will be highlighted.

To mark files in the gallery:

- Highlight **MARK** on the **GALLERY** menu and press ► or **SELECT** to select it.

The **MARK** option will flash to indicate that you are in marking mode.

- Use the **PREVIOUS** or **NEXT** to highlight the first thumbnail you want to mark, and press ► or **SELECT** to mark it.

The filename indicator will change to show that the file is marked:

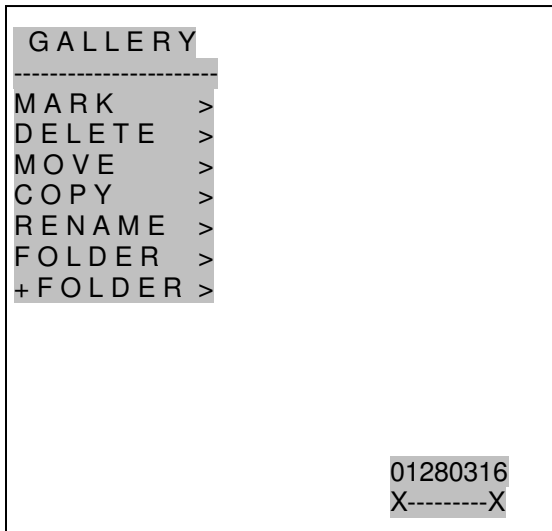

If necessary you can unmark a marked file by pressing ► or **SELECT** again.

- Mark other files in the gallery in a similar way.

When you have marked all the files you want to work with:

- Press **MENU** to exit from marking mode.

The **MARK** option will stop flashing.

- Highlight the option you want to apply to the marked files: **DELETE**, **MOVE**, or **COPY** and press ► or **SELECT** to select it.

- Proceed as described in the appropriate section below to perform the operation on the marked files.

To delete one or more files:

- Highlight **DELETE** on the **GALLERY** menu and press ► or **SELECT** to select it.

A **DELETE** menu will be displayed to allow you to confirm that you want to delete the selected file or marked files.

- Press **NEXT** to highlight **OK (SELECT)** and press ► or **SELECT** to select it

Alternatively to cancel the operation press ► or **SELECT** to select **CANCEL**.

To move or copy one or more files:

- Highlight **MOVE** or **COPY** in the **GALLERY** menu and press ► or **SELECT** to select it
A menu will allow you to confirm that you want to proceed.

- Press **NEXT** to highlight **FOLDER** and press ► or **SELECT** to select it

Alternatively to cancel the operation press ► or **SELECT** to select **CANCEL**.

A **SELECT FOLDER** menu will be displayed, showing a list of the names of each folder on the CompactFlash card.

- Highlight the folder you want to use and press ► or **SELECT** to select it.

The files will be moved or copied to the folder you specified.

To rename a file:

- Highlight **RENAME** in the **GALLERY** menu and press ► or **SELECT** to select it.

A **RENAME** menu will allow you to confirm that you want to proceed.

- Press **NEXT** to highlight **CHANGE** and press ► or **SELECT** to select it

Alternatively to cancel the operation press ► or **SELECT** to select **CANCEL**.

The **CHANGE FILENAME EDITOR** will be displayed:

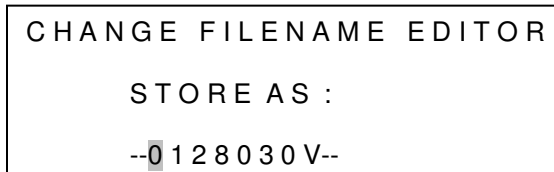

Edit the first six characters of the filename as follows:

- Press **PREVIOUS** or **NEXT** to step between the characters A—Z and 0—9
- Press ► or ◀ to step between the six character positions
- Press **SELECT** to return to the **GALLERY** menu.

You cannot change the two-character suffix.

To change the current folder:

- Highlight **FOLDER** in the **GALLERY** menu and press ► or **SELECT** to select it.

A **SELECT FOLDER** menu will show a list of names of the folders on the CompactFlash card.

- Highlight the folder you want to use and press ► or **SELECT** to select it.

The image gallery will be updated to show the 12 most recent files in the folder you specified.

To create a new folder:

- Highlight **+FOLDER** in the **GALLERY** menu and press ► or **SELECT** to select it

The **+FOLDER** menu will be displayed.

- Press ► or **SELECT** to select **DEFAULT** and create a folder with the default name **FOLDER** followed by a two-character suffix which is automatically incremented through the sequence **AA, AB...AZ, BA...** etc.

Alternatively, press **NEXT** to highlight **USER** and press ► or **SELECT** to select it to provide a custom folder name, in exactly the same way as renaming a file; see *"To rename a file."*

Adding Text Annotations

Using the OSD text editor

.....

Text annotations can be added to still images or video clips as they are captured. To use the text editor you need to connect a standard PC-AT keyboard with a USB connector to the keyboard input; see Left *Side Panel*. The **V5 Videoscope System** is compatible with either full-sized keyboards with 12 function keys or compact keyboards with 10 function keys.

The text editor allows you to enter up to 10 lines of 25 characters per line. In addition you can optionally display the current date and time on the bottom line of the screen.

To display the on-screen display:

- While a live image is being displayed, press **OSD**.

The on-screen display initially shows the text editor cursor on the second line of the display, and the date and time on the bottom line of the display.

- Enter the annotation text at the keyboard.
- Press **FREEZE** or **RECORD** to save the image or video clip in the usual way

The OSD will be saved as an overlay on the image.

Note that the OSD is not visible in the gallery thumbnails.

To hide or display the date and time

- Press ◀ or ▶

Note that the date display automatically switches between US MM/DD/YY format and European DD/MM/YY format depending on whether the video signal is NTSC or PAL respectively.

To edit the on-screen display

Use the following keys on the keyboard to edit the display:

Key	Description
↑, ↓, ←, →	Positions the cursor.
Del	Deletes the character to the right.
←	Deletes the character to the left of the cursor
Home	Positions the cursor in the top left-hand corner of the screen.
Enter	Moves the cursor to the start of the next line
Esc	Clears the on-screen display.
Shift or CapsLock	Allow you to enter upper-case

Note that the following characters cannot be entered:

|, \, ~, £, ¬, `

Storing standard annotations

.....

The text editor allows you to store up to 10 frequently used annotations, to save having to enter these at the keyboard each time you need them. The saved on-screen displays can also be edited before saving them with an image.

To create a standard annotation:

Press a functions key, **F1** to **F10**, corresponding to the number you want to assign to the annotation.

Initially each page contains **TEXT PAGE n**, where **n** is the page number.

The page number will be displayed in the center of the top line of the display.

- Enter the annotation you want to save.
- Press **Shift End** (or **Shift F12**) to save the contents of the page

To load a saved page

- Press the function key **F1** to **F10** corresponding to the number of the saved page.

NOTICE: Any text already in the text editor will be lost.

To enter scratch text:

- Press **Shift Esc**

You are then presented with a blank text editor, allowing you to enter a temporary annotation which will not be saved.

Adding Audio Annotations

Audio annotations can be added to video clips.

To connect the headphone set

- Plug the headphone set into the audio jack located on the Right Side Panel.

To record an audio annotation

- Record the annotation while the video is being captured in the usual way.

The audio annotation will be replayed while the video is reviewed from the gallery.

Setting up audio

.....
To display the audio settings:

- Disconnect the video source
- Press **SELECT**

The **AUDIO SETTINGS** menu will be displayed

AUDIO SETTINGS		

MUTE INPUT	OFF	<0>
MUTE OUTPUT	OFF	<0>
OUTPUT VOLUME		<5>
SELECT INPUT	MIC	<1>
AUDIO MONITOR	OFF	<0>

To mute the audio input or output

- Press **▲** or **▼** to highlight **MUTE INPUT** or **MUTE OUTPUT**, and press **▶** or **SELECT**

The value of the setting is highlighted with a flashing cursor.

- Use the **▲** or **▼** to change the setting between 0 (OFF) to activate the input or output, or 1 (ON) to mute the input or output.

When you have chosen the setting:

- Press **SELECT** to exit from editing mode.

When the audio input is muted, no recording is captured.

To change the audio output volume

- Press **▲** or **▼** to highlight **OUTPUT VOLUME** and press **▶** or **SELECT**

The value of the setting is highlighted with a flashing cursor.

- Use the ▲ or ▼ to change the volume between 0 (minimum) and 9 (maximum).

When you have chosen the setting:

- Press **SELECT** to exit from editing mode.

To select the audio input

- Press ▲ or ▼ to highlight **SELECT INPUT** and press ► or **SELECT**

The value of the setting is highlighted with a flashing cursor.

- Use the ▲ or ▼ to change the setting between 0 (AUX) and 1 (MIC).

Choose AUX for high-level line input, or MIC for a low-level microphone input.

When you have chosen the setting:

- Press **SELECT** to exit from editing mode.

To turn on or off the audio monitor

- Press ▲ or ▼ to highlight **AUDIO MONITOR** and press ► or **SELECT** to select it.

- Use the ▲ or ▼ to change the setting between 0 (OFF) and 1 (ON).

The audio monitor gives a copy of the input to the headphone; it is useful for testing the headset, or monitoring a line input.

Transferring Captured Images and Video to a PC

Installing a card reader

.....

Card readers are designed for use with USB 2.0 ports, and are compatible with USB 1.0

PCs running Windows 2000ME or later should recognize the card reader automatically, and install the appropriate driver when you plug it into the port, in which case you do not need to perform any installation.

If the card reader is working correctly, Windows will allocate a drive letter, such as D: or E:, to the reader. You can then use it just like another disk drive.

Formatting a CompactFlash card

.....

- Select **FORMAT** on the **MAIN MENU**, and press **SELECT** on the sub-menu.

NOTICE: This will erase any images already on the CompactFlash card.

After formatting a card there will be one folder named **FOLDERAA**.

NOTICE: If you have provided splashscreen files on the CompactFlash card, you will need to recopy these from a PC after formatting the card.

Copying files to the PC

.....
To copy images or video clips from a CompactFlash card to the PC, simply drag them from the drive allocated to the CompactFlash card, and copy them to a suitable disk on your PC.

The images are stored in standard JPEG (.JPG) format, and can be edited or printed from any suitable application, such as Paint Shop Pro.

The video clips are stored in QuickTime (.MOV) format and can be replayed using **QuickTime Player**, available for free download at: <http://www.apple.com/quicktime/download/>

Copying files to the CompactFlash card

.....
Images created by the **V5 Videoscope System** and edited on the PC, can be copied back to the **V5 Videoscope System** card for subsequent display on the **V5 Videoscope System**.

You can also create JPEG images on the PC, and copy them to the **V5 Videoscope System** for display. In this case, the JPEG image must be the correct size and aspect ratio for the PAL or NTSC display. In addition, it must comply with the JPEG baseline image specification, and be encoded in 4:2:2 format for correct color rendition.

NOTE: If image files are copied back onto a CompactFlash card from a PC, the order of the files will be determined by the PD directory listing order, which is not the same as the order in which they were captured. Unfortunately, there is no way to modify this.

6.0 VIDEO DISPLAY

The knob on the monitor bezel labeled BRIGHTNESS set the monitor back light intensity. To adjust Monitor parameters, see Digital Video Recorder Description and Operation section.

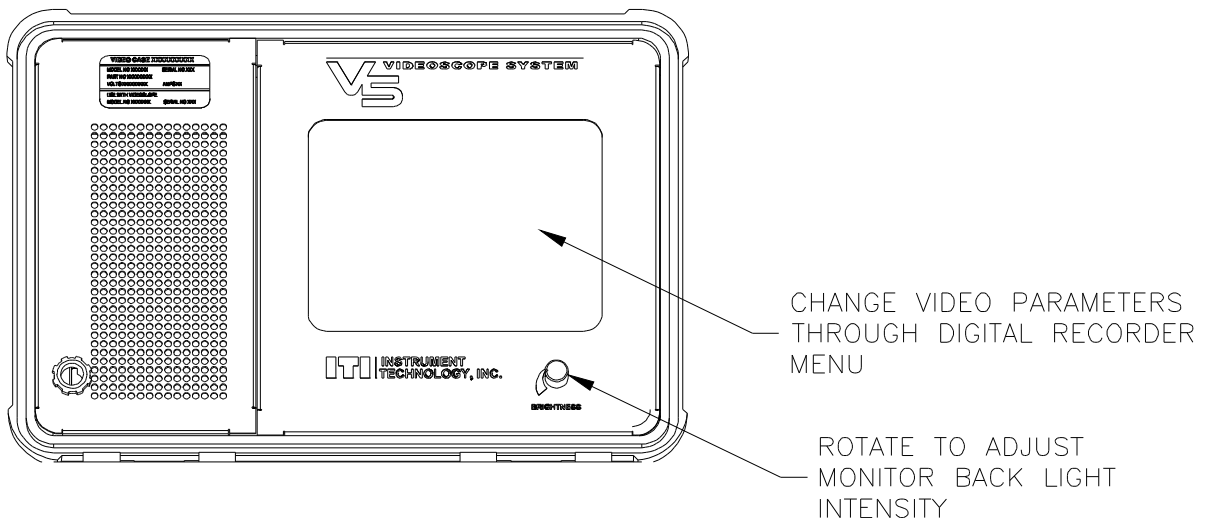

Fig. 6: Video Display

Display options

.....

Select **DISPLAY ORIENTATION** on the **MAIN MENU**, and press **SELECT** on the sub-menu

To rotate the display

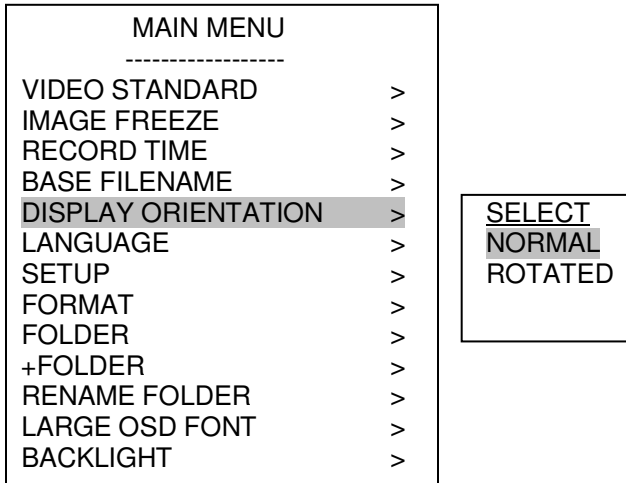

Inverts the display on the monitor. The operation of the ▲ and ▼ keys is also reversed.

PICTURE QUALITY

Adjust light output to accommodate inspection area. Highly reflective surfaces require minimal illumination, see Light Source manual. To adjust the Video Processor, see Control Panel.

7.0 BATTERY AND CHARGER

The V5 Videoscope System (V5) contains two 12VDC Battery packs. They are located under a cover in the lower left corner of the V5 case. There are also two optional battery packs supplied with the kit, they are located in the foam in the bottom of the large travel case. Also located in the travel case are two battery chargers and their power supplies. The batteries can be charged while they are in the V5 case or they can be removed from the V5 case and charged one at a time.

The V5 Videoscope System (V5) is designed to operate using external 115VAC or internal 12VDC supply. The V5 will automatically switch to internal 12 VDC if the 115VAC is disconnected. If the 115VAC is reconnected while running on internal 12VDC power the VIP may shut down. To reset the V5 turn the Main Power switch OFF and back ON.

NOTICE: The V5 will not operate on internal 12VDC batteries when the Battery Chargers are connected. Swap with the spare batteries and charge the batteries externally if the unit needs to be operated off 115VAC power.

Charging the batteries inside the Videoscope System (V5) case.

NOTICE: It is best practice to charge the batteries outside of battery compartment to reduce heat build up due to charging. High temperature will shorten battery life and degrade overall battery performance (e.g. capacity runtime.) Excessive high temperatures may cause batteries to become physically damaged and lead to damage of collateral equipment.

1. Turn main power switch to the OFF position.
2. Unplug the V5 from the AC power source.
3. Remove all the cables connected to the Videoscope.
4. Review the Battery Charger Specifications (see Battery Charger).
5. Plug both chargers into the connectors in the Rear Power Panel.

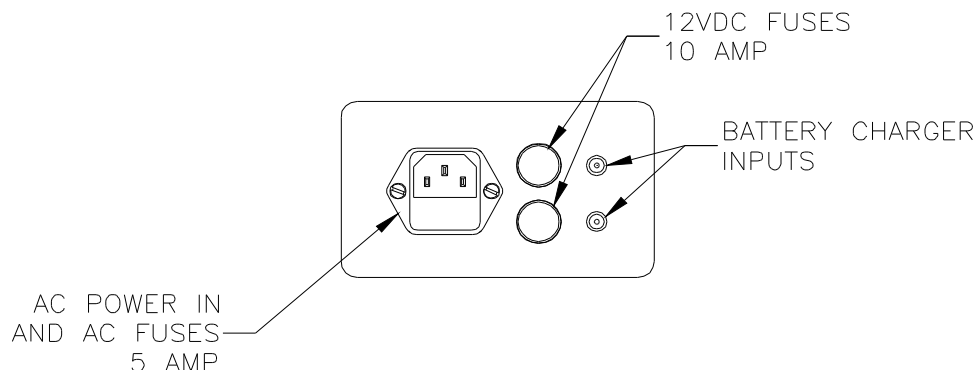

Fig. 7: Rear Power Panel

Charging the batteries outside the V5 Videoscope System (V5) case.

1. Turn main power switch to the OFF position.
2. Unplug the V5 from the AC power source.
3. Remove all the cables connected to the Videoscope.
4. Remove the batteries from the V5 case:
 - a. Slide the battery cover off.
 - b. Lift the batteries out by their lifting tab.
 - c. Disconnect the battery from the connector by pulling on the wire, not the battery.
5. Review the Battery Charger Specifications (see Battery Charger).
6. Plug the battery into the charger as explained in the Battery Charger Specifications (see Battery Charger).
7. Replace the batteries into the case:
 - a. First insert the plug into the hole, the connector is at the bottom of the hole.
 - b. Push on the strain relief until it is flush with the hole, a small tool maybe needed.
 - c. Place the Battery Packs in the compartment with the “pig tails” toward the center.
 - d. Replace and secure cover with retaining screw.

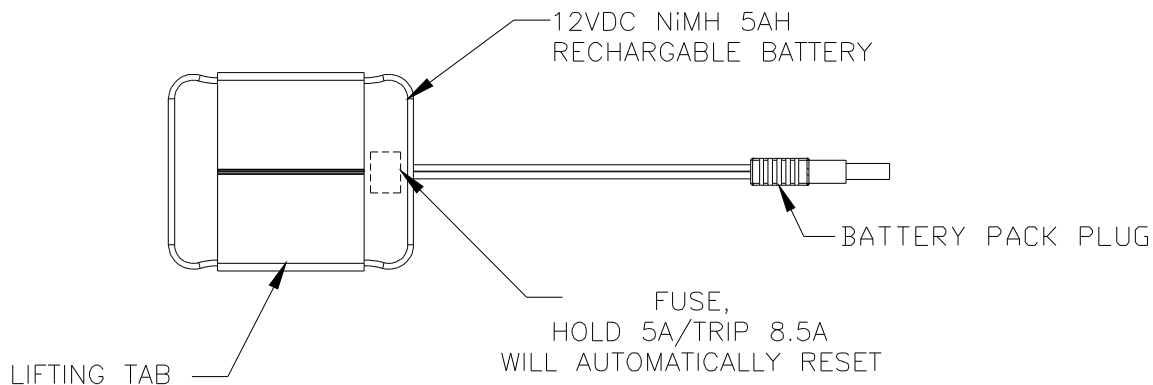

Fig. 8: 12VDC Rechargeable Battery Pack (P/N B120903)

Battery Charger

Specifications:

1. Input Voltage: 100-240 VAC, 50/60 Hz
2. Charger Type: Ni-MH Battery Packs (6 thru 10 cells)
3. Charging Current: 0.9A or 1.8A (switch selectable)
4. Trickle charge current: 0 - 250mA
5. Battery Size: 1.2Ah to 14Ah
6. Output Voltage: 16V nominal

LED indications:

- Black: Power On, but no battery connected
- Red: Charging
- Green: Charged/Trickle Charging

The -delta V rapid charging battery charger has incorporated a microprocessor for controlling the charging process.

Charger output is equipped with a 5.5 mm OD x 2.1 mm ID barrel plug. The charger is supplied with an IEC AC cord which has an IEC-C13 socket.

Connect the battery pack plug to the charger output plug, and plug the input cord into an 115V AC outlet. Allow approx. 3hrs at 1.8A **OR** approx. 6hrs at 0.9A to fully charge a battery pack.

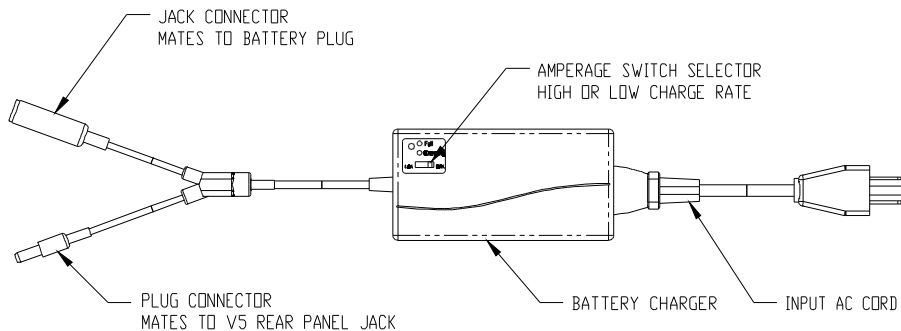

Fig. 9: Battery Charger (P/N C120866-3)

CAUTION:

- Do not recharge packs which are hot to the touch; allow them to cool down to ambient temperature first.
- Use the charger only to recharge packs consisting of cells of the same type and capacity.
- The charger may become hot when operating – take care when touching the unit.
- Do not cover the charger, provide adequate cooling.
- Keep the charger, batteries and cables away from flammable or temperature sensitive objects.

8.0 LIGHT SOURCES

The side panel the **V5 Videoscope System (V5)** contains three light sources. Using the Light Source Selector switch located on the light source to the far left is the High Intensity White Light Source. The center light source is the Infra Red (IR) Light Source. The light source to the far right is the Blue Light Source. Depending on configuration set up one or more of the sources may be omitted.

▲ WARNING: The high intensity light at the front of the light sources and the tip of the Videoscope probe will create high temperatures and bright light. To minimize the risk of injury, avoid direct viewing or contact.

To prevent injury due to bright illumination and contact with heated parts, always plug the fiber optic bundle into the light source before turning the power on.

▲ CAUTION: Since the high intensity white light source uses a custom lamp, always have a spare lamp available for replacement. **USE CAUTION WHEN REPLACING LAMP BECAUSE IT MAY BE HOT.** Allow lamp to cool before replacing.

NOTICE: Do not switch the high intensity white light source ON and OFF in rapid succession. Doing so will dramatically shorten lamp life. Allow lamp to cool down at least 15 seconds between each use.

8.1 WHITE LIGHT SOURCE

The high intensity light source is used to supply high quality, white light for video illumination.

NOTICE: Do not restart the high intensity white light source immediately after shutting it off – it may fail to start. If this occurs, turn the power OFF and wait a minimum of 15 seconds before turning the unit back on.

1. Plug the fiber optic bundle into the light source before turning the power on. Turn the light intensity control to the minimum position by rotating the lever to the most down position
2. There are two switches to activate the high intensity light source. First the rotary switch on the Top Control Panel must be rotated to the White Light position. Second the rocker switch on the face of the light source must be pushed to the ON position. The lamp will take 10 to 15 seconds to complete the warm-up cycle.
3. Set the light intensity to the desired level by rotating the lever up and down.
4. Turn the Light Source Select Switch to OFF position when not in use.

Lamp Replacement

▲ CAUTION: Lamp may be hot. Allow lamp to cool before replacing.

1. Turn off the high intensity light source, turn off the Main Power switch on the Control Panel, and unplug the **V5 Videoscope System (V5)** from the AC source.
2. Unscrew the Drawer Lock Screw, pull out the light source drawer until it stops and the lamp is exposed.
3. Open the lock and remove the lamp by pulling it back and up against the retaining spring, then disconnect the black lamp connector. Note that the notch is at the bottom of the porcelain ring.
4. Replace with ITI replacement lamp (Part No 408-078) only. **DO NOT** touch the lamp itself, or the interior reflective surface of the lamp. Skin oils on the lamp will cause premature lamp failure. Hold the lamp by the outside of the reflector or the connector only. Remove any grease or fingerprints on the lamp with a clean Q-tip moistened with alcohol. Do not leave lint on the lamp.
5. Reconnect the lamp to the connector and insert lamp so that the alignment pin is properly seated in the bracket. Flip the lock back in place.
6. Push the drawer in and tighten the drawer locking screw.

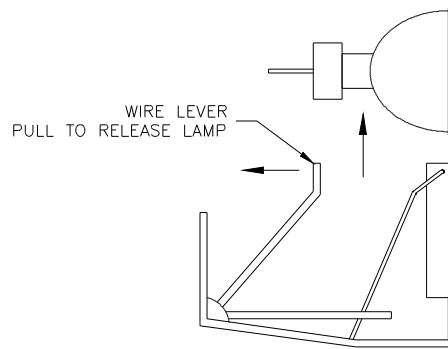
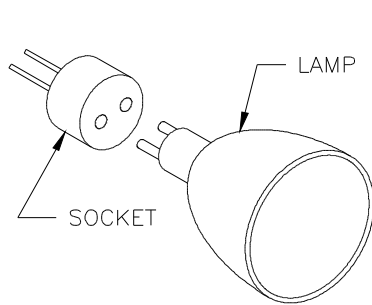

Specifications

Lamp: ITI part number 408-078

Color Temperature: 5500 K

Lamp: 60 Volts, 24 Watts, 2.6 amps DC

Lamp life: 500 hours

Dimming System: Manual shutter (light intensity control)

8.2 BLUE LIGHT SOURCE

The Blue Light Source is used to supply a narrow frequency, high intensity, blue light, when a white light source is not appropriate for video and optical illumination.

1. The Blue Light Source will illuminate best if the White Balance (see Top Control Panel) is in the SET mode. While the White Balance is in the AUTO mode view a well lit white surface illuminated with white light, then push the switch to change to SET mode. This will lock the White Balance and prevent the camera from trying to compensate for the Blue Light.
2. Plug the fiber optic bundle into the light source before turning the power on. Turn the Light Intensity Control to the minimum position by rotating the lever to the most down position.
3. Turn the rotary switch on the Top Control Panel to the Blue Light position.
4. Set the light intensity to the desired level by rotating the lever up and down.
5. Turn the Light Source Select Switch to OFF position when not in use.

NOTICE: the Blue LED light source has no user replaceable parts. Contact ITI if repair is required.

Specifications

Lamp: Royal Blue LED

Wave length: 440 nm peak emission

Lamp: 8 to 24 Volts DC, 5 Watts, 700 mA

Lamp life: more than 5000 hours

Dimming System: Manual shutter (light intensity control)

8.3 INFRARED (IR) LIGHT SOURCE

The IR Light Source is used to supply a, high intensity, IR light, when a visible white light source is not appropriate for video and optical illumination.

1. The IR Light Source will illuminate best if the White Balance (see Top Control Panel) is in the SET mode. While the White Balance is in the AUTO mode view a well lit white surface illuminated with white light, then push the switch to change to SET mode. This will lock the White Balance and prevent the camera from trying to compensate for the IR Light.
2. Plug the fiber optic bundle into the light source before turning the power on. Turn the Light Intensity Control to the minimum position by rotating the lever to the most down position.
3. Turn the rotary switch on the Top Control Panel to the IR Light position.
4. Set the light intensity to the desired level by rotating the lever up and down.
5. Turn the Light Source Select Switch to OFF position when not in use.

NOTICE: the Infrared LED light source has no user replaceable parts. Contact ITI if repair is required.

Specifications

Lamp: Infra Red LED

Wave length: 880 nm peak emission

Lamp: 10-14 Volts DC, 6 Watts, 400 mA

Lamp life: more than 5000 hours

Dimming System: Manual shutter (light intensity control)

9.0 HEADPHONE SET

For adding audio annotation to a video clip, a headphone set and a 6Ft long patch cord are included in the kit. The discreet lightweight design offers exceptional sound quality. Due to the flexible ear hook, the headphone can be attached to the left or to the right ear. All the controls are built into the headset. For quick storage the unit folds up.



Fig. 10: Headphone Set

10.0 HANDLE MOUNTED 4" MONITOR (OPTION)

A handle mounted monitor is available for user convenience. The monitor option can be configured either of two ways (1) with the power and video cable external to the Videoscope, or (2) with power and video wiring internal to the scope. In either configuration the monitor is secured to the handle in either of two ways (1) clamp style mount and (2) integrated handle mount respectively. The former is recommended for occasional users, while the latter for the frequent user. The convenience of the wiring is the primary difference.

Integrated Connection

This is the configuration described and illustrated in this document. The Videoscope must be built or retrofitted with the factory installed integrated connector for this monitor configuration.

The Monitor receives power and signal from the 4 pin connector located on the Videoscope hand piece. The connection is also the threaded mount for the monitor. Both the integrated and external cabled monitors connect directly to the 4-socket Video Output connector on the V5 Videoscope System side panel, see Fig. 2

Operating Instructions:

1. Mount the monitor to the Videoscope hand piece.
2. If configured with an external monitor cable, also secure the cable along the Videoscope control cable.
3. Connect power/video cable to the V5 Videoscope the 4-socket Video Output connector on the V5 Videoscope System side panel, see Fig. 2

NOTICE: An external monitor can not be connected to the Auxiliary Video Out, on the side panel, at the same time the Detachable Monitor is connected.

4. With the **V5 Videoscope System** turned on and with an image on the monitor in the lid, power on the monitor and adjust the controls as required.

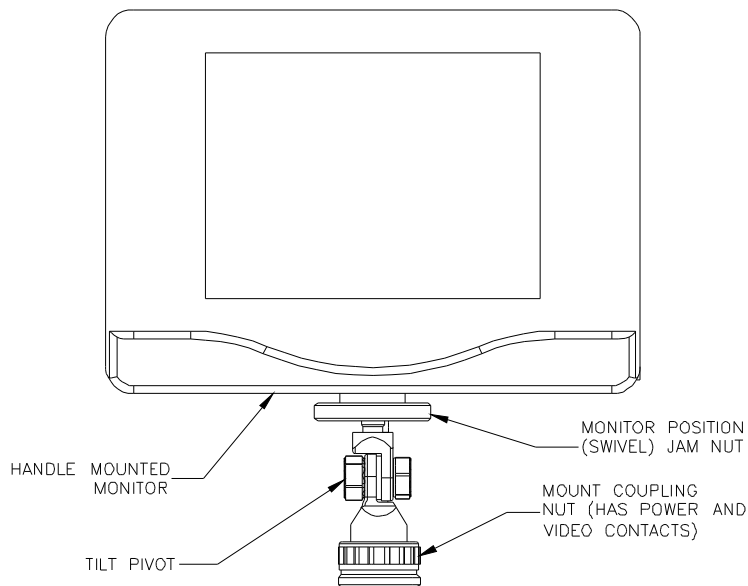

Fig. 10: Detachable Monitor (Integrated Configuration Shown)

11.0 WIRELESS LINK (Option)

The V5 Videoscope System can be configured with a video transmitter to enable the use of a remote monitor. The remote monitor requires a remote wireless receiver operating at the same frequency (listed below) as the transmitter, such as the ITI Receiver Pack shown.

11.1 TRANSMITTER, VIDEO CASE

A wireless link is available to connect the V5 Videoscope System to a remote monitor. The transmitter is located inside the V5 Videoscope System case and is controlled with the Transmitter Control Panel.

Operating Instructions:

CAUTION: Never power up the transmitter without the antennae attached, transmitter damage will occur.

1. With the V5 Videoscope System powered up turn on the transmitter using the panel's slider switch labeled ON/OFF.

NOTICE: The Power indicator light should be illuminated at this time.

2. Rotate the antenna to the vertical position.
3. Set the transmitter channel selector to the same channel as the ITI Receiver Pack.

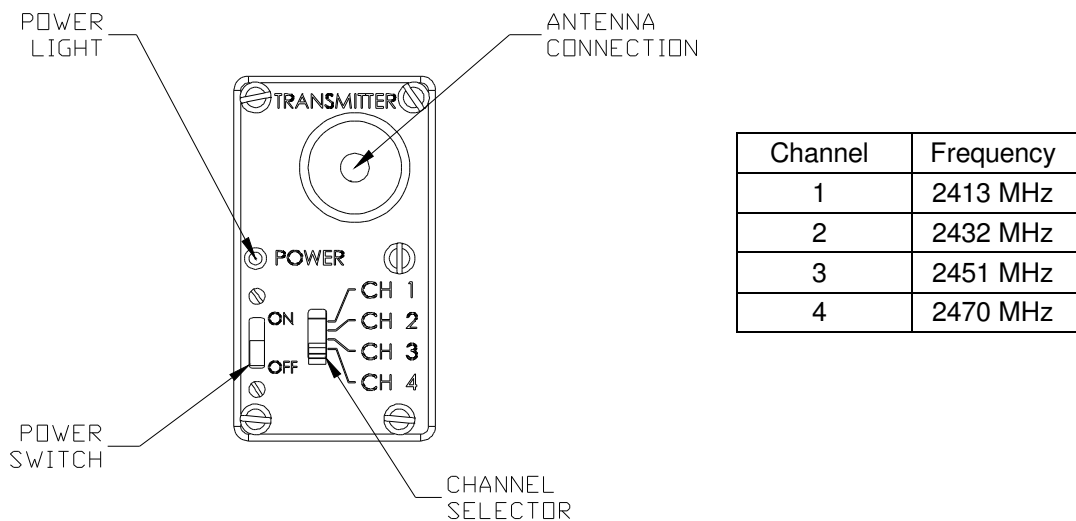

Fig. 11: Transmitter Control Panel

11.2 RECEIVER PACK (Accessory Option)

Using the V5 Videoscope System's transmitter with a remote monitor requires a wireless receiver. The ITI Receiver Pack is compatible with the V5 system and requires only a power/video cable configured to mate it to a 12VDC power supply and a monitor. The receiver is frequently used with ITI's Monitor Pack and Head Up Display, both have a viewing display monitor. The receiver can be configured with a custom cable for use with an existing monitor and power supply.

Operating Instructions:

1. Connect the 4-pin video cable to the Wireless Receiver's 4-socket video out connector.
2. Connect the power supply or the battery pack cable to the power jack found on the side of the receiver..

NOTICE: An LED power indicator light will be illuminated if the receiver is receiving power. If the power indicator is not illuminated check the electrical connection and power supply.

3. Rotate and raise antenna vertically.
4. Set the Channel Select Switch to the same channel as the transmitter. The channel selector is located on the Top Control Panel.

NOTICE: An LED is provided to indicate the transmitted signal is being received. If the signal light is not illuminated, ensure the receiver channel selector matches the transmitter. Distance and Radio Frequency (RF) reflecting, retarding, and grounding structures will also degrade the wireless signal and performance.

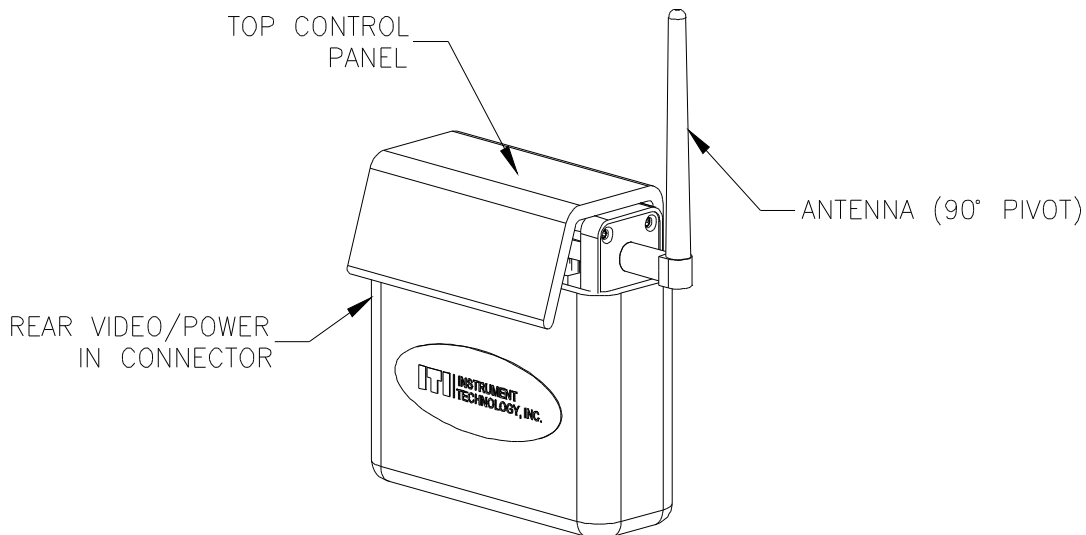

Fig. 12: Wireless Receiver

12.0 HEAD UP DISPLAY (OPTION)

SPECIFICATIONS

ITI Model 126395 Heads Up Display includes:

- (1) Monocular Head-Up Display with Inline Interface Control Box and connector
- (1) Pair of Eye Glasses
- (1) Eye Glasses Protective Case

OVERVIEW OF APPLICATION

This kit is intended to provide maximum resolution, portability and quick setup.

Installation & Mounting

CAUTION: CAMERAS AND HUD ARE DELICATE INSTRUMENTS, AND SHOULD BE TREATED ACCORDINGLY. PROPER HANDLING AND CLEANING TECHNIQUES WILL GREATLY INCREASE THE LIFE OF THIS INSTRUMENT. ONLY TRAINED OPERATORS SHOULD HANDLE THIS EQUIPMENT.

Fitting the HUD

The HUD was designed to be mounted on a variety of ballistic eyewear. The HUD has a small clip, resembling a paper clip that slides onto the edge of the glasses. This clip provides a stable and quickly removable mount to the eyewear.



Fig. 13: HUD Glasses

Using the Control Box

- The top button, coming from the glasses, is Power ON/OFF.
- The middle button is used to flip the display from right eye to the left eye.
- The bottom 2 buttons are brightness controls and allow you to adjust the brightness up or down, depending on light conditions.

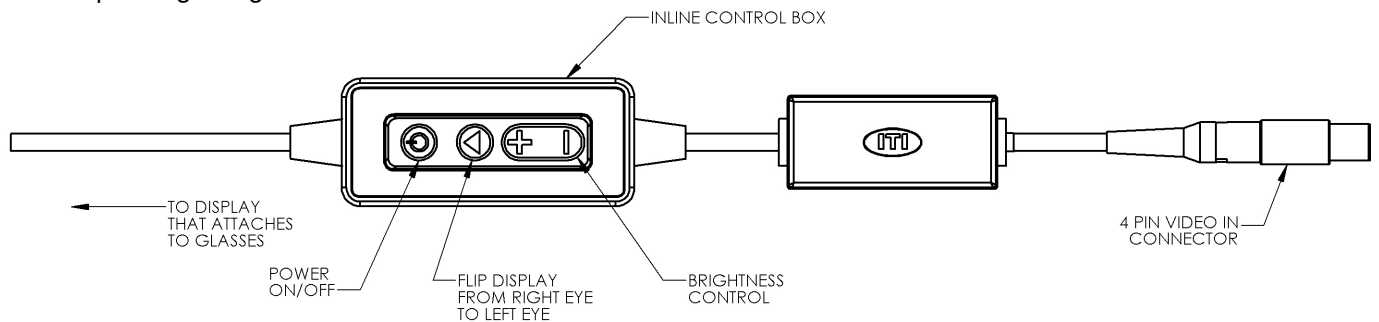





Fig. 14: Inline Control Box Cable

Connecting the HUD assembly to the video source

The HUD connects to the power / video source thru a 4 pin connector attached at the end of the Inline Control Box cable.

For operating instructions, see the attached Head Up Display operations manual.

13.0 TROUBLESHOOTING GUIDE

SYMPTOM	POSSIBLE PROBLEM	REMEDY
Dark Image 	Low Light Source [LS] intensity setting	Increase LS intensity
	Object distance too far or object is extremely dark	Use higher intensity LS
	Dirt on external optical surfaces	Clean optics
	Damaged Light Guide - noticeable damage to LG jacket	Return to ITI for repair
Image Not Clear 	Dirt on external optical surfaces	Clean optics
	Object distance is out of scope's range	Move scope to proper object distance
	Dirt or liquid on internal optical surfaces	Return to ITI for repair
No Image 	No or low LS intensity	Check LS
	Dirt on external optical surfaces	Clean optics
	Scope is damaged	Return to ITI for repair

14.0 INSTRUMENT CARE

CLEANING AFTER USE

Wipe instrument after use with a soft, clean cloth. If instrument is soiled, use a non-abrasive, neutral detergent on a damp cloth to clean it. Always store the instrument in a protective case.

NOTICE: DO NOT IMMERSE INSTRUMENT IN LIQUID unless it has been specifically manufactured for underwater applications.

CLEANING OF OPTICS

Should cleaning of external surfaces be necessary, blow off dust with a triple-filtered, high pressure optical quality dusting spray. Wipe surface with a clean cotton swab moistened with laboratory grade alcohol. Excess alcohol can be blown away with the spray.

ITI Model 126110 RVI Cleaning Kit may be used.

CAUTION: Do not use beyond recommended temperatures, otherwise property damage to this instrument or collateral property may occur.

Maximum 150° F (65° C)

Minimum 32° F (0° C)

⚠ DANGER: Do not allow instrument to contact live or exposed wiring. It is an excellent conductor.

Repair Policy

If your equipment requires factory attention, contact ITI's Customer Service Dept. at (413) 562-3606 for a Return Authorization Number. Please be prepared to furnish your model and serial numbers. Return the equipment to ITI, freight prepaid.

Ship to:

Instrument Technology, Inc.

33 Airport Road

Westfield, MA 01085-1357

NOTICE: Please note Return Authorization Number on Purchase Orders and all shipping documents.

Upon receipt of your equipment, ITI will assess its condition to determine if repairs are needed. If repairs are required, we will quote repair costs and a schedule for repairs. Your options at this point are:

1) Accept Repair

To proceed with the repair, ITI will require a purchase order for the full quoted repair price.

2) Decline Repair - Upgrade to a New Instrument

Choosing this option requires a purchase order for the new equipment at its quoted price. ITI will ship out the next available unit.

3) Decline Repair

Please Note - Most repair evaluations require a partial or complete disassembly of the equipment. **Once disassembled, it is impossible to return it to the customer in "as received" condition.** At the customer's option, ITI will either return your equipment in its disassembled state, or dispose of it.